



Cellwood Machinery
FOR BETTER PULP AND PAPER

KRIMA Disperser TYPE KD



KRIMA

CELLWOOD
MACHINERY

KRIMA DISPERSER TYPE KD
A RESULT OF 40 YEARS' EXPERIENCE AND
CONTINUOUS DEVELOPMENT.



Krima Disperser type KD

KRIMA DISPERSER TYPE KD:

- Optimum performance.
- Low energy consumption.
- Different dispersing discs.
- Long lifetime.
- Easy maintenance.
- Many reference plants.
- Discharge consistency 3 - 35 %.
- Capacity range 10 - 1200 tpd.

KRIMA Disperser

TYPE KD

KRIMA Disperser is a further developed disc refiner suitable for high consistency treatment. The best results are reached when the inlet consistency is between 20 and 35 %.



The technically superior and patented infeed zone allows treatment of all types of fibers without risk of blocking.

The infeed zone also contributes to the very low energy consumption 35-45 kWh/ton of pulp. The power consumption varies according to the type of dispersing discs and operating temperature.

The Disperser provides a high pumping effect which feeds the pulp directly to the required station, i.e. machine vat or storage tower.

In order to achieve maximum pumping effect, the rotor can be equipped with special pump flights.

An outlet consistency of up to 15 % can be reached in the standard disperser housing. A high consistency outlet can be, reached by using HC dispersing house configuration.

DESCRIPTION

The KRIMA Disperser is mounted on a baseplate on which the main motor is also situated. This arrangement allows a perfect alignment between the disperser and the motor shaft.

All parts in contact with the pulp are manufactured in acid-proof steel. All other parts are sandblasted and coated with an epoxy-paint. The protective covers for the coupling and lubrication system are manufactured in polished stainless plate. The inspection openings are covered with plexiglass.

DISC GAP SETTING

The disc gap can be adjusted either by mechanical-hydraulic or electro-hydraulic systems. Adjustment can take place during operation with either method and possibility of remote control is standard. The setting accuracy with both methods is 0.01 mm.



CONTROL PANEL

The Control Panel includes the electronic system DGC for disc gap control as well as the alarms and maintenance functions.

The Control Panel will be made according to customer's requirements and is manufactured of a water proof stainless steel cabinet with plexiglass covered door.

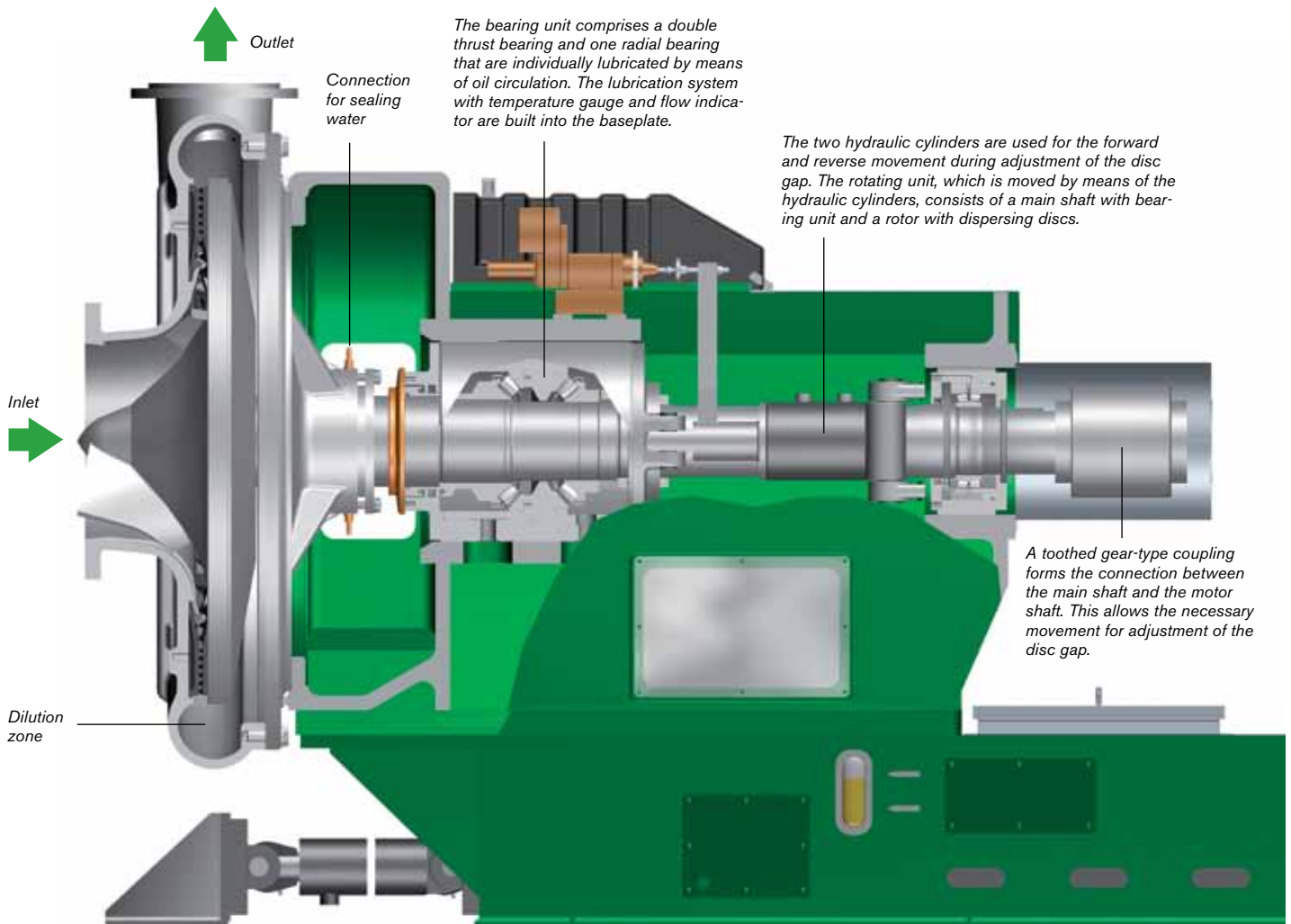

DISPERSING DISCS

Cellwood Machinery AB has produced special dispersing discs that allow the fibres to be treated as gently as possible and at the same time completely disperse the contaminants. These discs also ensure a low energy consumption.

Dispersing discs are available in different "deviltooth" patterns to give the best optimum result. Flexible discharge consistency from 3 – 35 %.

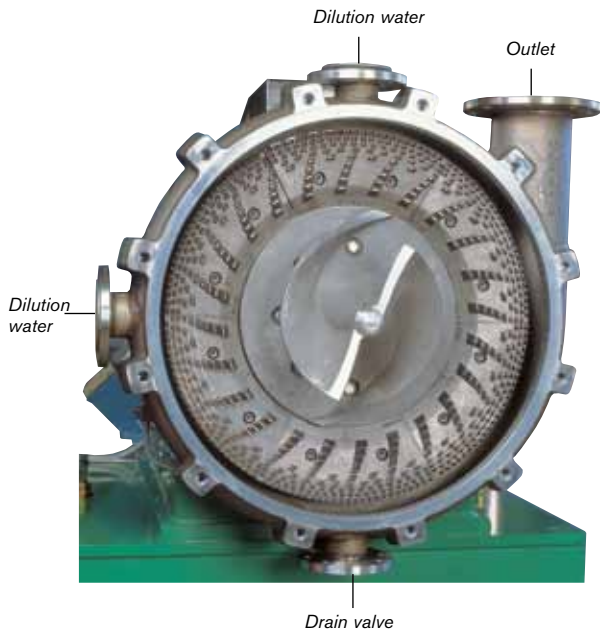

Discharge consistency 3 – 15 %



Discharge consistency 25 – 35 %

SERVICE

KRIMA Disperser has a unique service function for easy and fast maintenance.

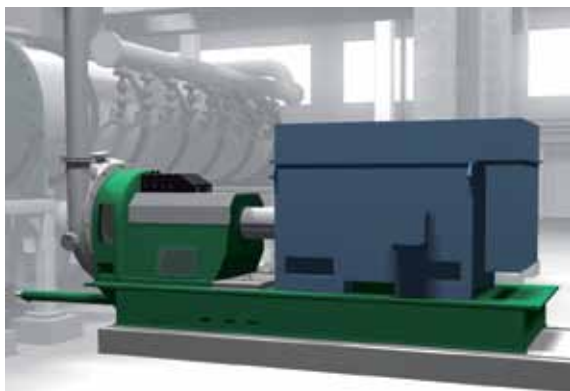

Disperser closed

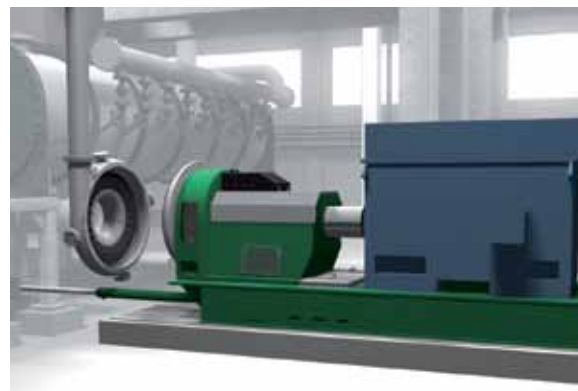

Disperser open

TECHNICAL DATA

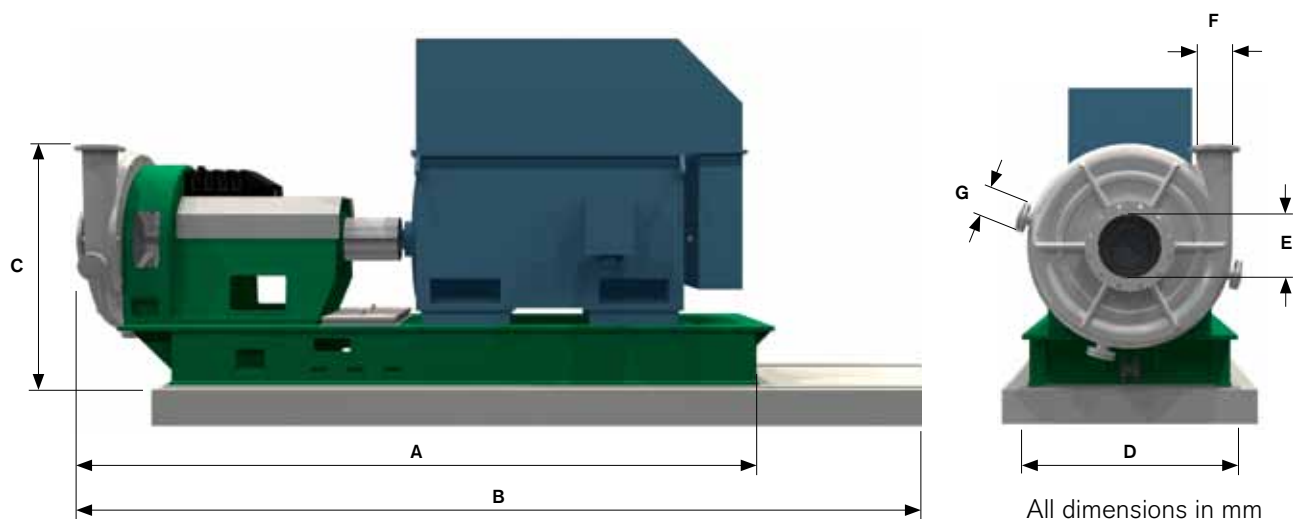

Type (Size)	Disc Ø	Speed rpm (60 HZ)	Length A	Service l. B	Height C	Width D	Inlet Ø E	Outlet Ø F	Dilution water Ø G	Weight kg excl. motor
KD-450	450	1200/1500	3350	4250	1215	1250	250	125	DN40 (2pcs)	3800
KD-710	710	1200/1500	3700	4600	1350	1250	350	150	DN80 (3pcs)	4000
KD-1050	1050	1200/1500	4450	6000	1650	1450	400	200	DN80 (4pcs)	6500
KD-1250	1250	1200/1500	5550	-	1750	1600	500	300	DN100 (4pcs)	7000

CAPACITY FIGURES

Capacity values for the Krima Disperser type KD will vary because the type KD may be used for various materials. The following values may be used as guidelines for high consistency dispersing.

Type of Disperser

KD-450	0 - 70 TPD
KD-710	50 - 300 TPD
KD-1050	250 - 800 TPD*
KD-1250	750 - 1200 TPD

Inlet consistency

6 - 35 %

Outlet consistency

3 - 35 %

Installed motor

KD-450	90 - 250 kW
KD-710	160 - 800 kW
KD-1050	710 - 2000 kW
KD-1250	1800 - 3000 kW

*Outlet consistency min.10 % between 600-800 TPD.



Cellwood Machinery AB • Box 65 • SE-571 21 NÄSSJÖ • SWEDEN • Phone +46 380-760 00 • Fax +46 380-141 23
Street address • Storgatan 53 • SE-571 32 NÄSSJÖ • SWEDEN • E-mail sales@cellwood.se • www.cellwood.se